

MANWAY DETAIL

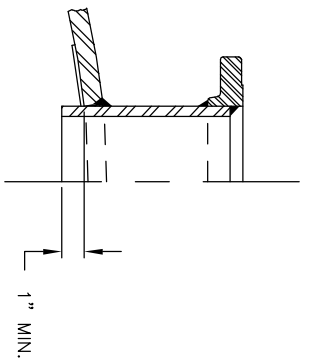

6" NOZZLE DETAIL

NO. QTY	DESCRIPTION	SPEC	SUB-DWG.
S1 1			
S2 1			
H1 2			
C1 2	1 NPT 3000# FULL COUPLING	SA-105	
C2 1	3 NPT 3000# HALF COUPLING	SA-105	
C3 1	1/4 NPT 3000# FULL COUPLING	SA-105	
C4 2	1.1/4 NPT 3000# HALF COUPLING	SA-105	
F1 2	6" 150# ANSI RF. SO. FLANGE	SA-105	
F1 2	6" SCH.80 PIPE X 7 1/2" LONG	SA-106-B	
M1 1	.134 X 8 5/8" O.D. X 6 5/8" I.D. BACKING RING	C1008	
M1 1	12" X 16" X 3/4" X 4" 300# MANWAY	SA-106-C	
S3 1	STANDARD 8" SKIRT ASSEMBLY FOR 84" DIA. TANK		A86006
A1 4	1" X 6" X 6" STANDARD LIFT LUG		A86004
A2 3	3/16" X 2" X 260 3/16" BACKING RING		
NP 1	ASME DATA PLATE		

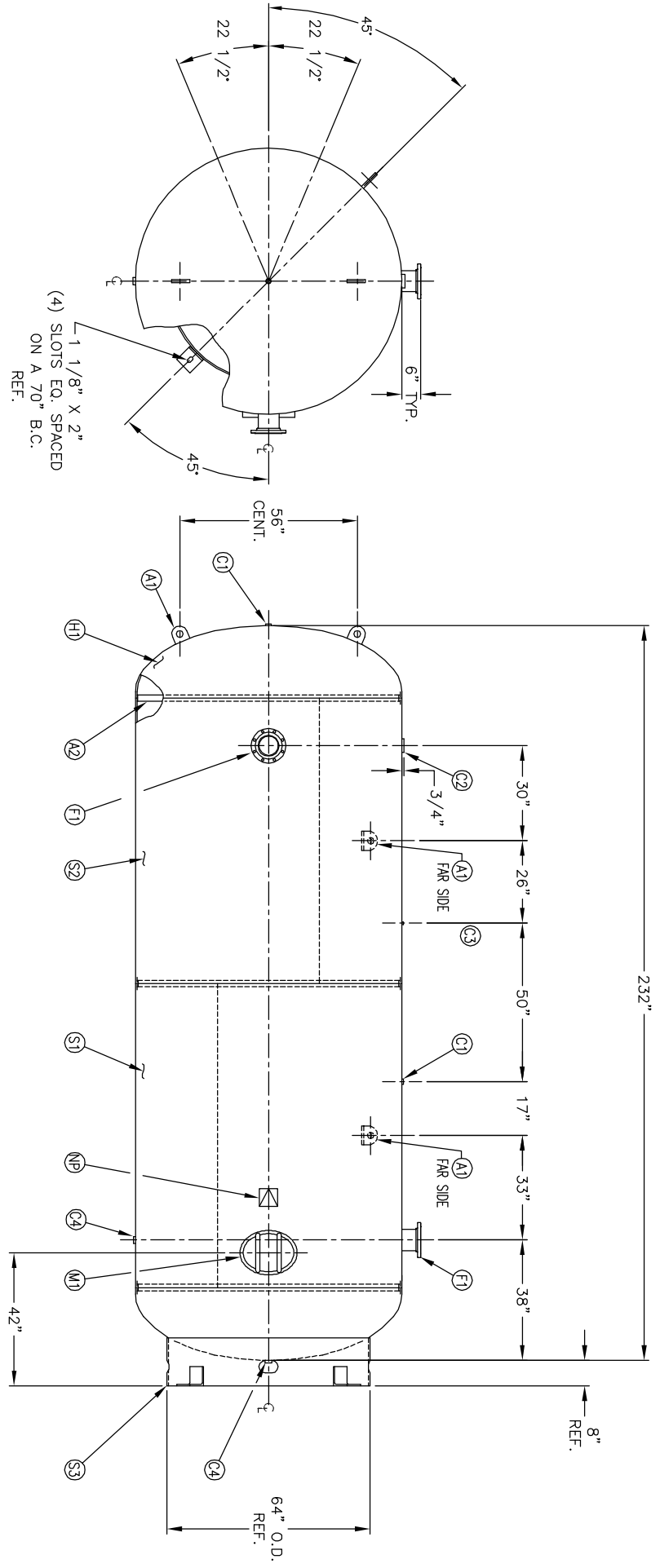

SYMBOL	DATE	BY	REVISION	APP. XREF. REV.	NOTES	SPECIFICATIONS
A	JC	JC		AMA		O.D. 84 LGH. 232 MANIP 165 PSI @ 450 F RT - MDMT -20 F @ 165 PSI EXMT TEST CRN --- WELD DETAILS: M-1932 STD. TOLERANCES (UNLESS OTHERWISE NOTED): M-2461
B	JC	JC		JC		GALL. 5000 S.A. 455.01 WT. 10500 CU.FT. 683.69 CORR ALW SH HD CODE ASME SECT. VIII, DIV. 1 PER DATE OF DWG/LAST REV

**MANCHESTER TANK**  
G:\3000

84" X 232" VERT.  
STANDARD AIR RECEIVER

DRAWN BY	DATE	SCALE:	NONE
APP. BY	DATE	DRAWING NO.	302459